

Technical data



Project name
Position/Item
Customer reference
Our reference

TK1

Date
Project notes
Position notes

14.5.2019 11:48

Fan type Plug fan CF3D - PM
Fan code **GMPM-1-00-090-8540**
Pcs 1

Fan data
Max fan speed 1375 r/min
Airflow sensor k_factor 5.77

Input values
Volume flow rate 8.900 m³/s
Input static pressure 700 Pa

Connection
Connection: Free Inlet - Free outlet
AHU dimensions Width 0 mm
AHU dimensions Height 0 mm

Output values
Volume flow rate 8.900 m³/s
AHU connection loss 0 Pa
Other losses 0 Pa
Fan static pressure 700 Pa
Fan speed 1155 r/min
Total sound power level 92.4 dB(A)
Shaft power -- kW
Power from mains Ped 9.200 kW
Overall static efficiency 67.7%
SFP 1.034 kW/m³/s

Gas properties
Density 1.200 kg/m³
Temperature 20.0 °C
Humidity 50.00%
Elevation 0 m

Weight
Fan 207.0 kg
Motor -- kg
Accessories -- kg
Total 207.0 kg

Fan data according to ISO 5801 and ISO 13347-2. Sound data below is calculated for selected connection method.
The octave sound power level near BPF can be higher than calculated below.

Lwoct (Hz)	63	125	250	500	1000	2000	4000	8000	Lwt (dB)	LwA (dBA)
Free outlet	79.5	92.5	91.5	89.5	88.5	83.5	78.5	73.5	97.1	92.4
Free inlet	84.5	94.5	88.5	85.5	82.5	79.5	74.5	68.5	96.5	88.2

Motor code **AMPM-13-8585-30-08** **Speed controller** PM built-on

Motor type
Motor power 15.00 kW
Nominal speed 1375 r/min
Motor efficiency -- %
Efficiency class IE4
Motor current 35.20 A
IEC-size 132

Drive power 15.00 kW
Calculated operating Hz 57.7 Hz
Calculated operating voltage 8.0 V
Max speed with motor 1375 r/min
Calculated max Hz 68.8 Hz
Nominal input current 33.00 A
Power supply 400V 3~50Hz
Fan nominal power -- kW

Accessories

Data according to ErP-directive

Overall efficiency ned 71.9%
Efficiency grade N 75
Input power Ped 16.080 kW
Volume flow rate 8.863 m³/s
Pressure 1305 Pa

ErP 2015 Compliant

Speed 1375 r/min
Target efficiency grade N 62
Installation category A
Efficiency category static
VSD Yes

TÜV classification B0
DIN 24166 classification LK 1

Fan chart



Project name
Position/Item
Customer reference
Our reference

TK1

Date
Project notes
Position notes

14.5.2019 11:48

Fan	GMPM-1-00-090-8540	Connection	
Fan type	Plug fan CF3D - PM	Connection: Free Inlet - Free outlet	
Pcs	1	AHU dimensions Width	0 mm
		AHU dimensions Height	0 mm

Output values			
Volume flow rate	8.900 m ³ /s	SFP	1.034 kW/m ³ /s
AHU connection loss	0 Pa	Fan chart density	1.200 kg/m ³
Other losses	0 Pa	Operating density	1.200 kg/m ³
Fan static pressure	700 Pa		
Fan speed	1155 r/min		
Total sound power level	92.4 dB(A)		
Power from mains Ped	9.200 kW		
Overall static efficiency	67.7 %		

GMPM-1-00-090-8540

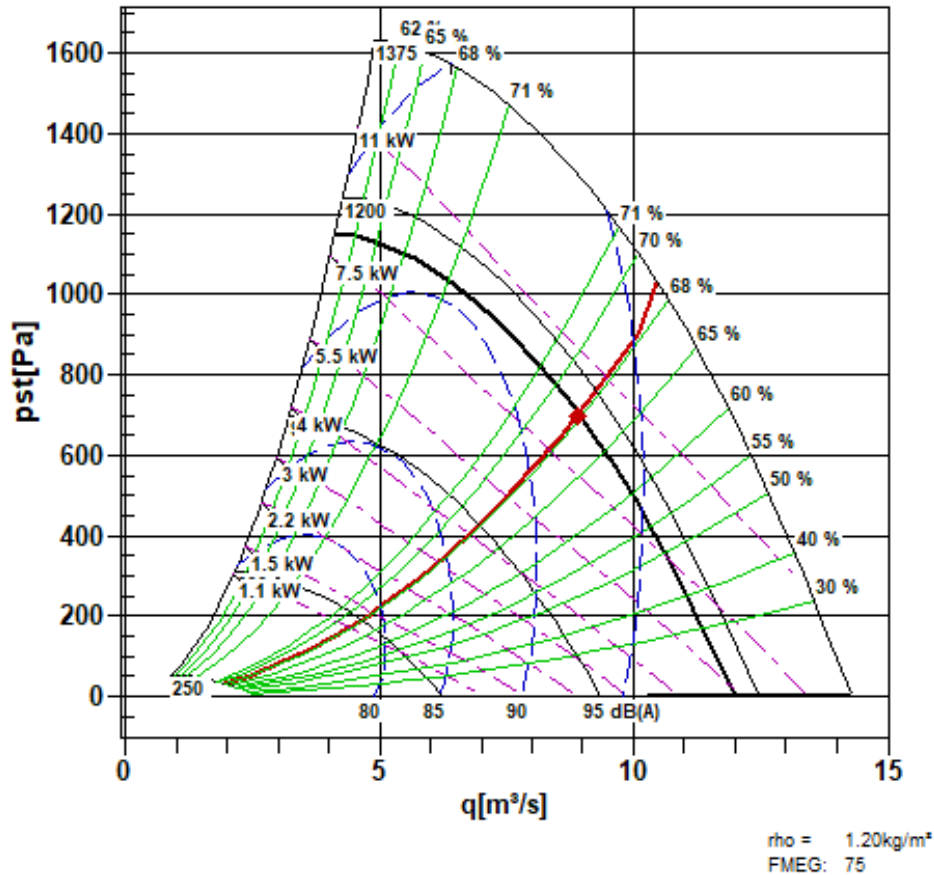

Dimensions



Project name
Position/Item
Customer reference
Our reference

TK1

Date
Project notes
Position notes

14.5.2019 11:48

Item number: **GMPM-1-00-090-8540**
 Item type: Plug fan CF3D - PM
 Qty: 1

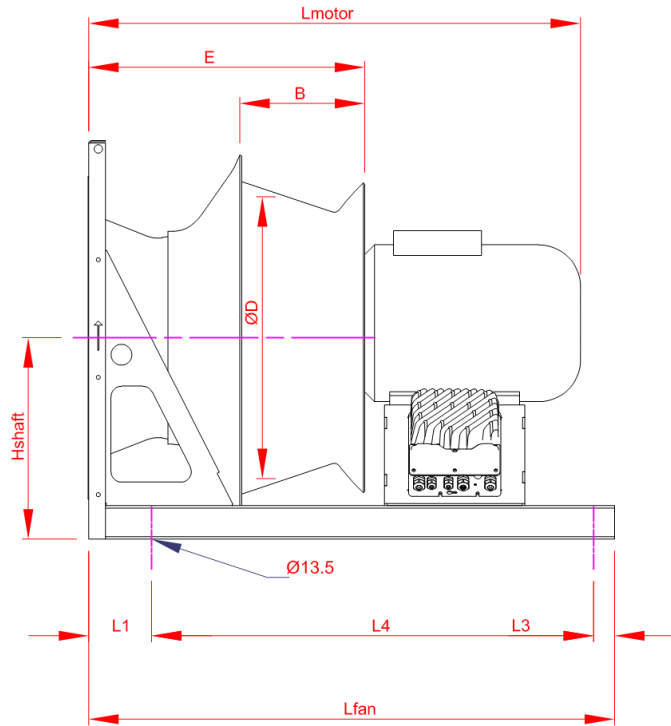
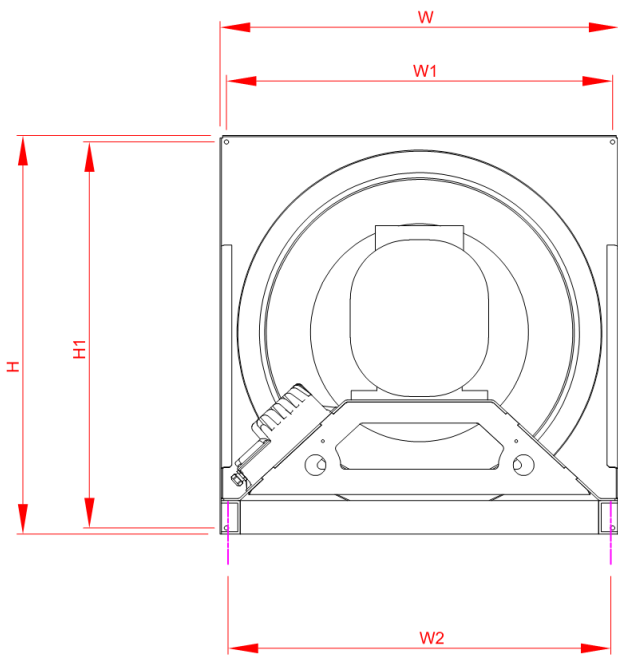

Dimensions	mm	Dimensions	mm
D	980	Lmotor	1187
Ø	326	Lfan	1253
N	1180	Lfc	0
N1	1150	E	733
N2	1142	L1	110
Nfc	0	L2	0
h	1180	L3	50
h1	1150	L4	1093
hshaft	590	M	--